



**FKG**  
architecten  
aan de Zaan

**BGSV**

bureau voor stedenbouw en landschap

Opdrachtgever	STED Development
Project	De Vrijheid
Locatie	Hoorn
Werknummer	2523
Fase	Advies buurt
Datum	13 april 2022

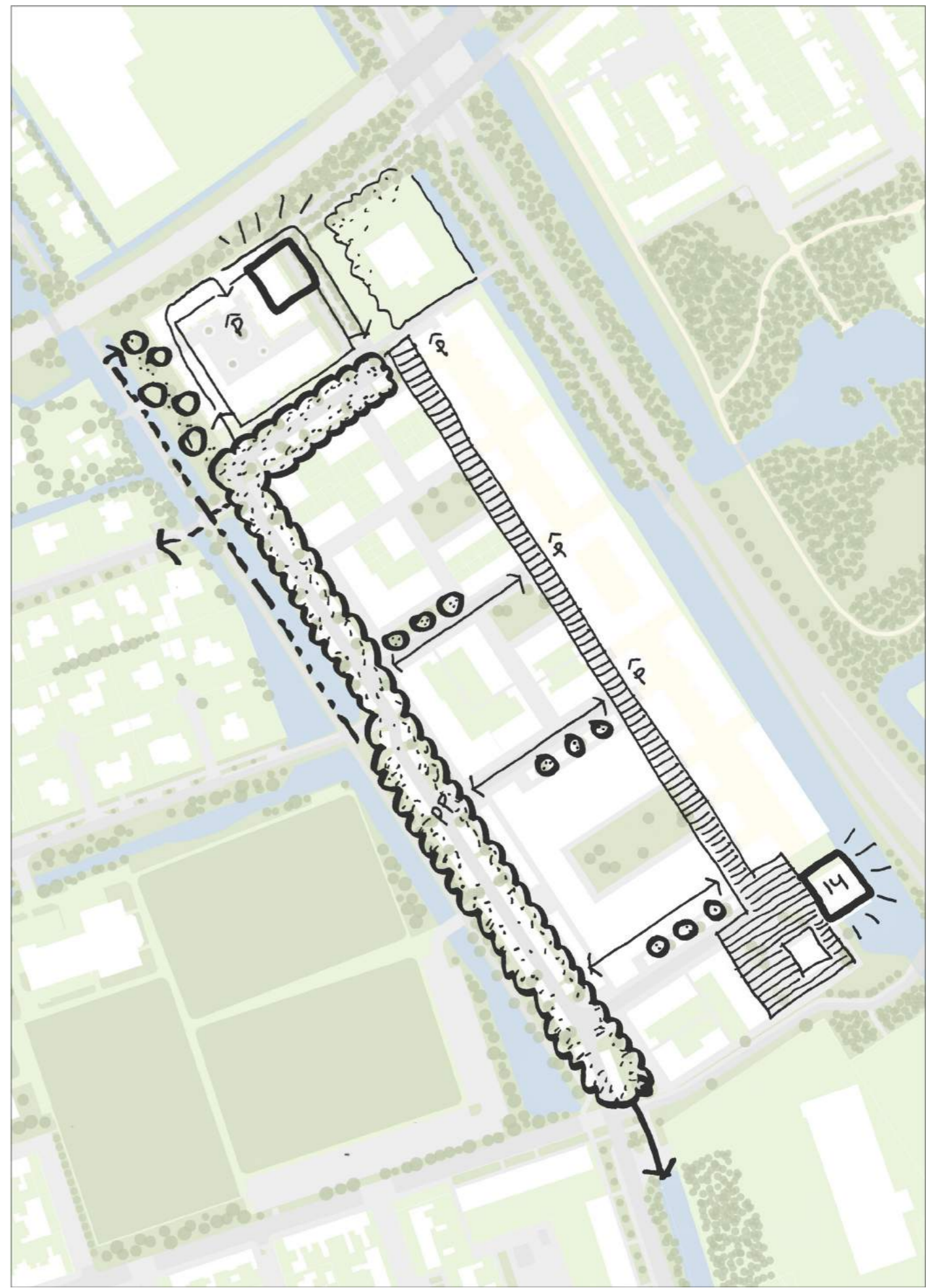
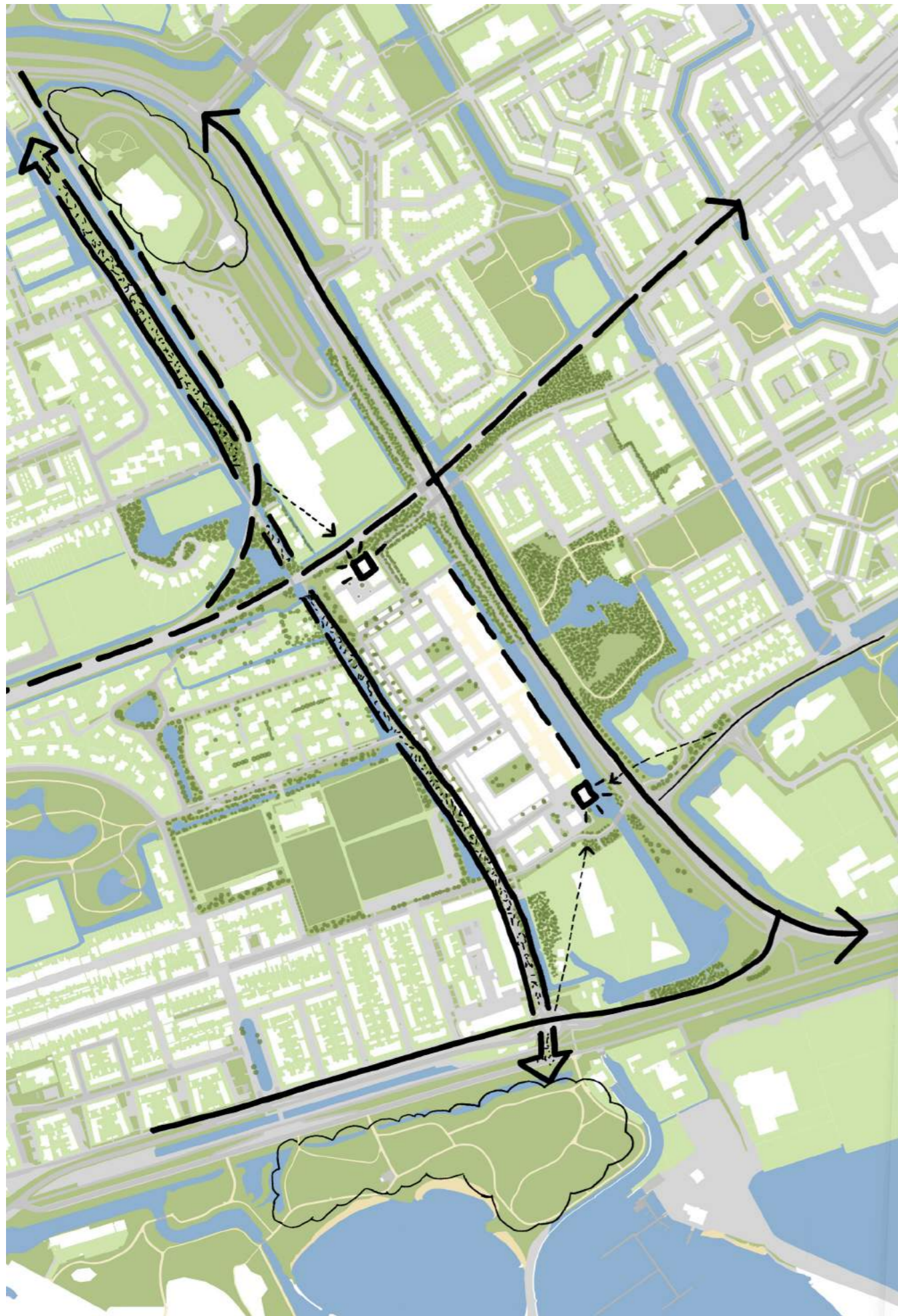



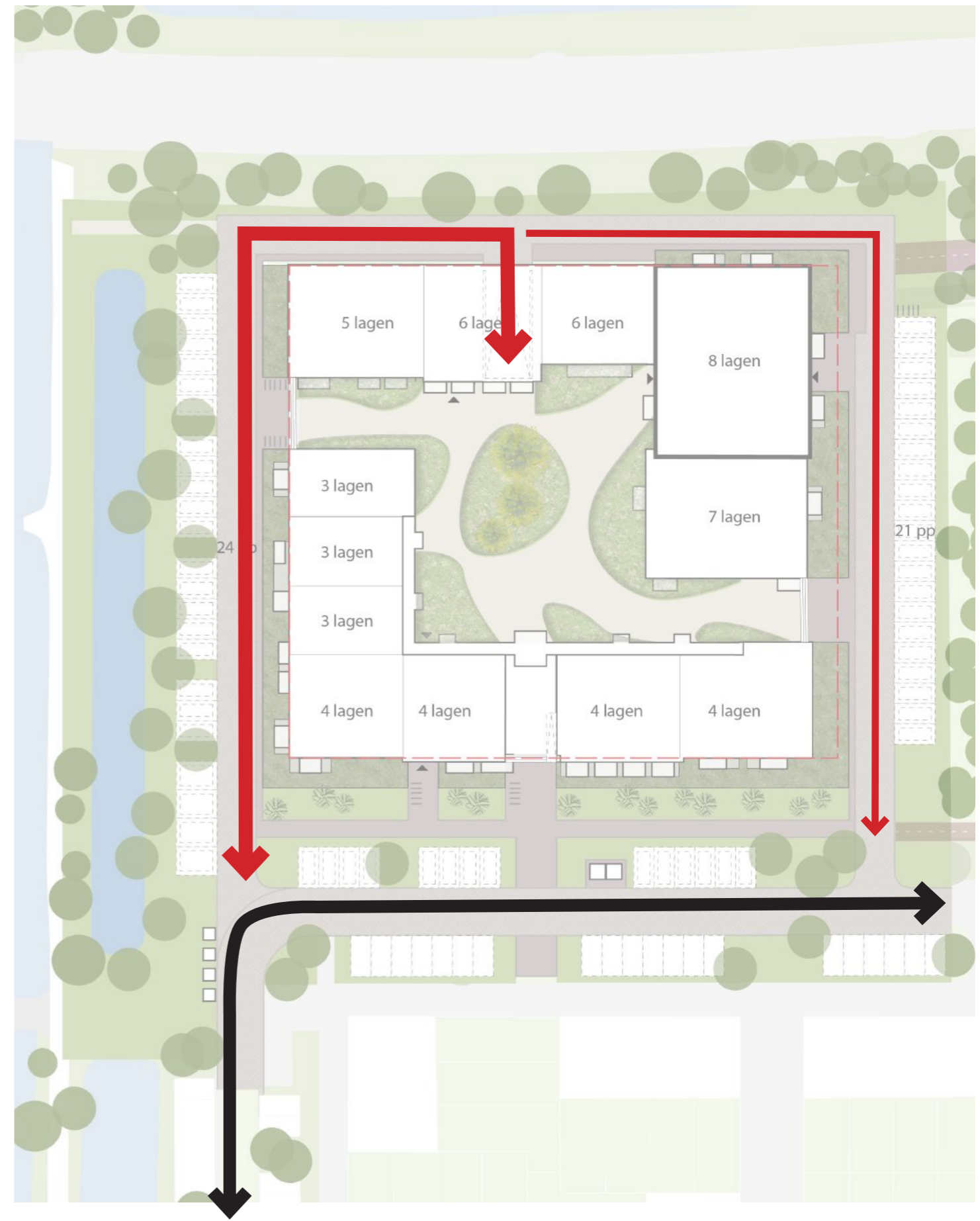



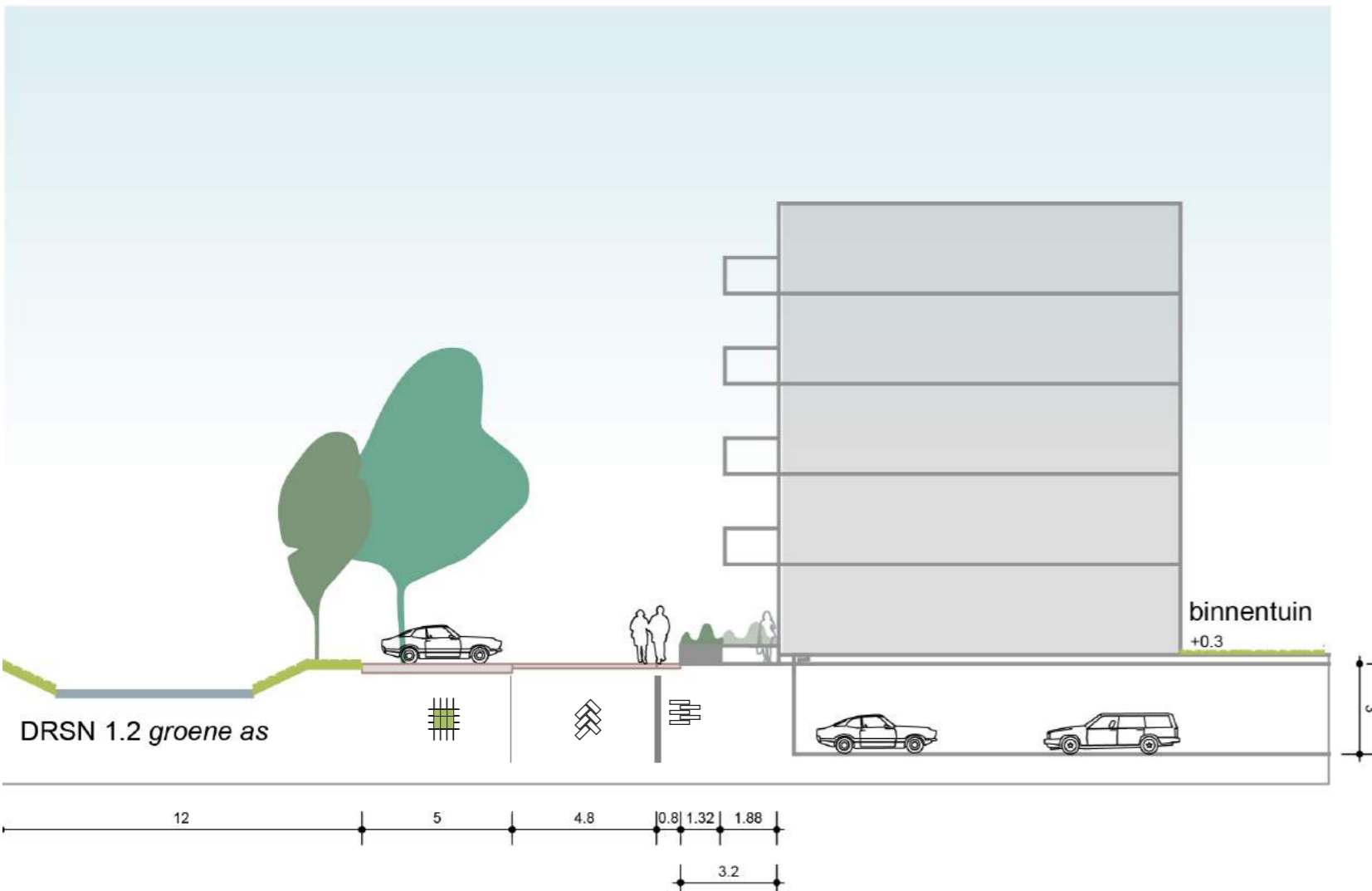

groene omzoming - bloem- en kruidenrijk



grasbetonstenen met uitstapstrook



verlaagde band als markering en afwatering



verhoogde plantenbak omkadert buitenruimte



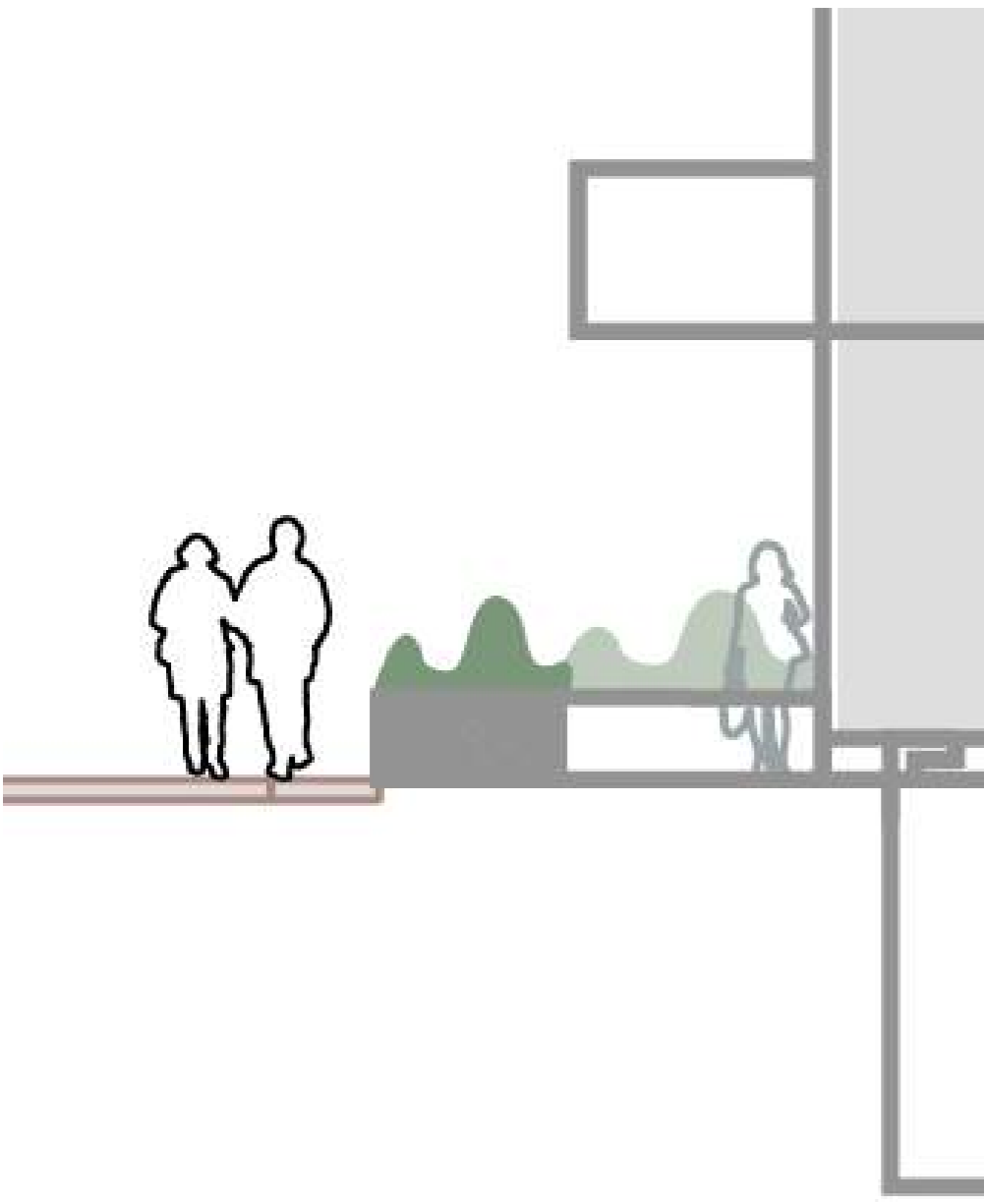
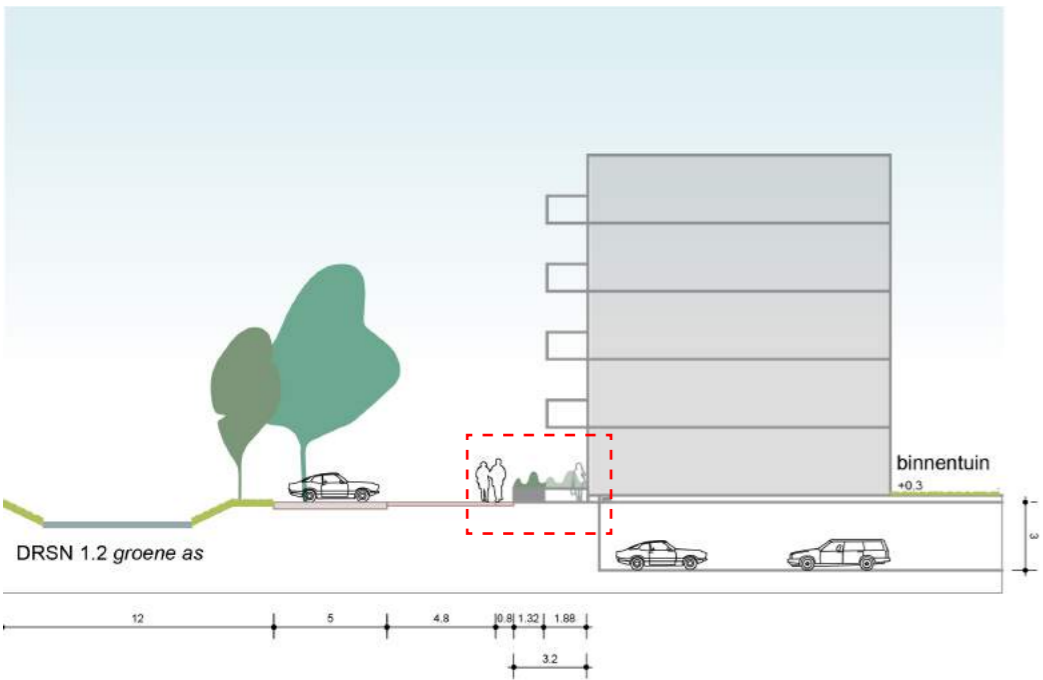

bloemrijke border met her en der een bloeiende heester

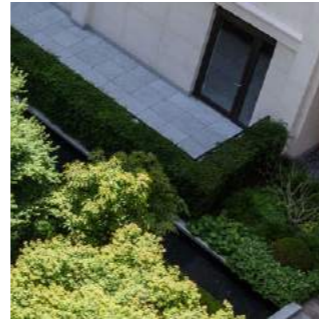

omzoomt door een groenblijvende haag: o.a. ilex, Portugese olijfwilg of liguster



groene aangrenzende zone met gestrooide bomen en her en der een bloeiende heester, o.a. krentenboom of magnolia





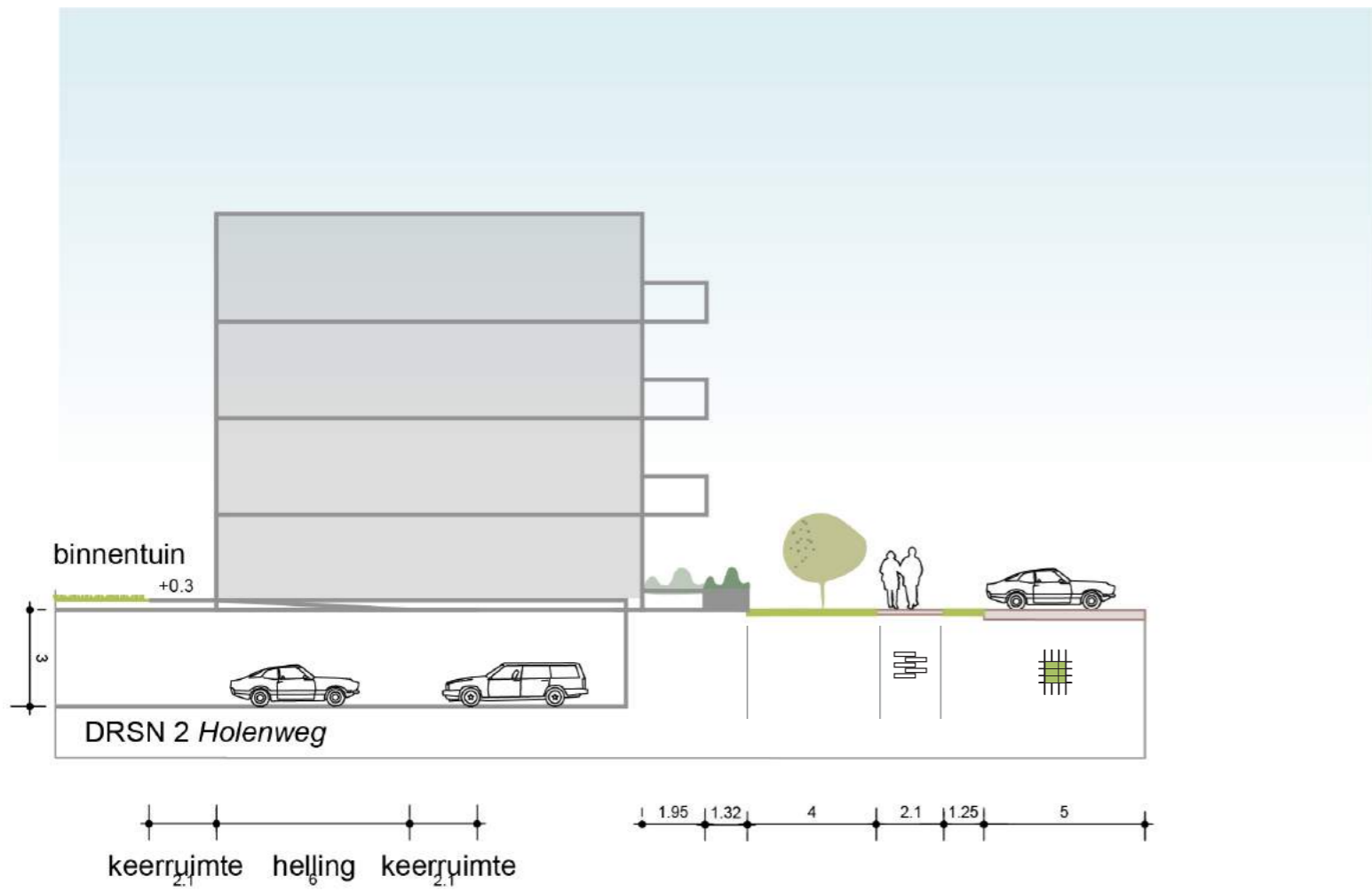

groene omzoming - bloem- en kruidenrijk



verhoogde plantenbak omkadert buitenruimte



groenstrook met losse meerstammige bomen



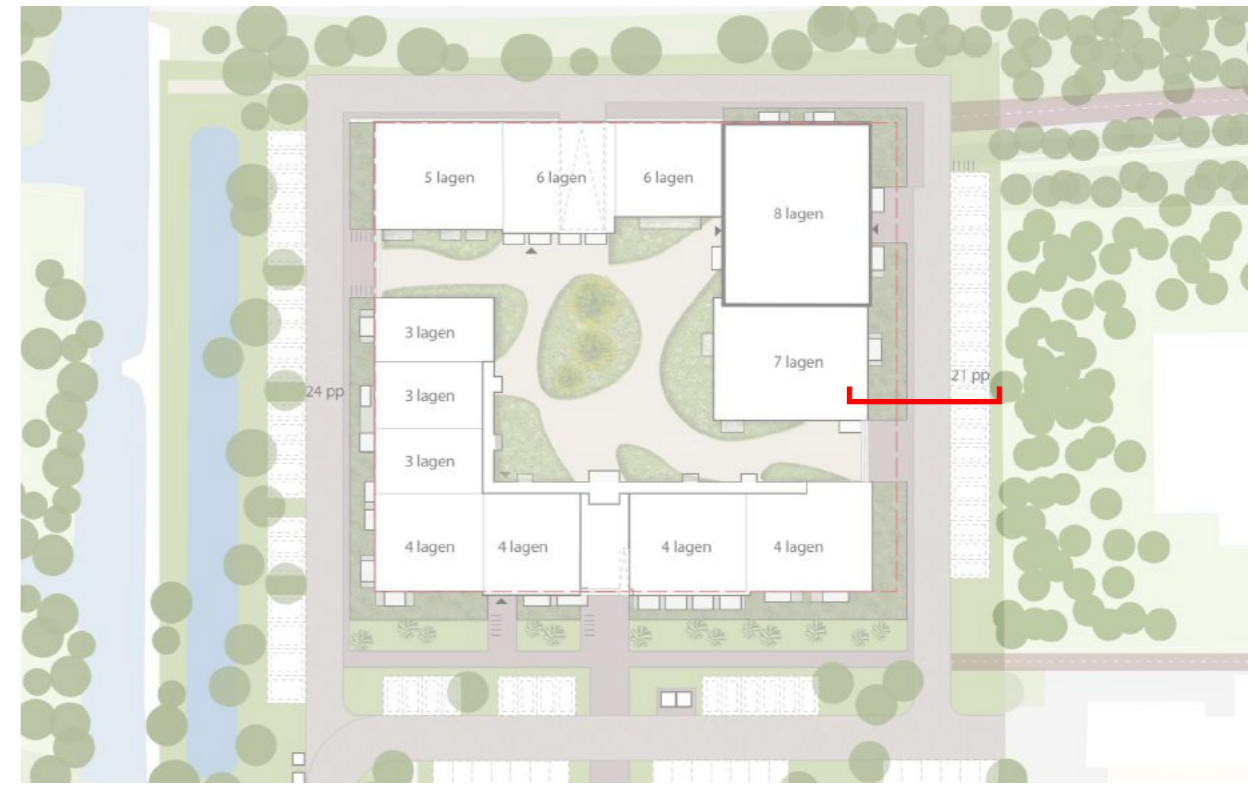
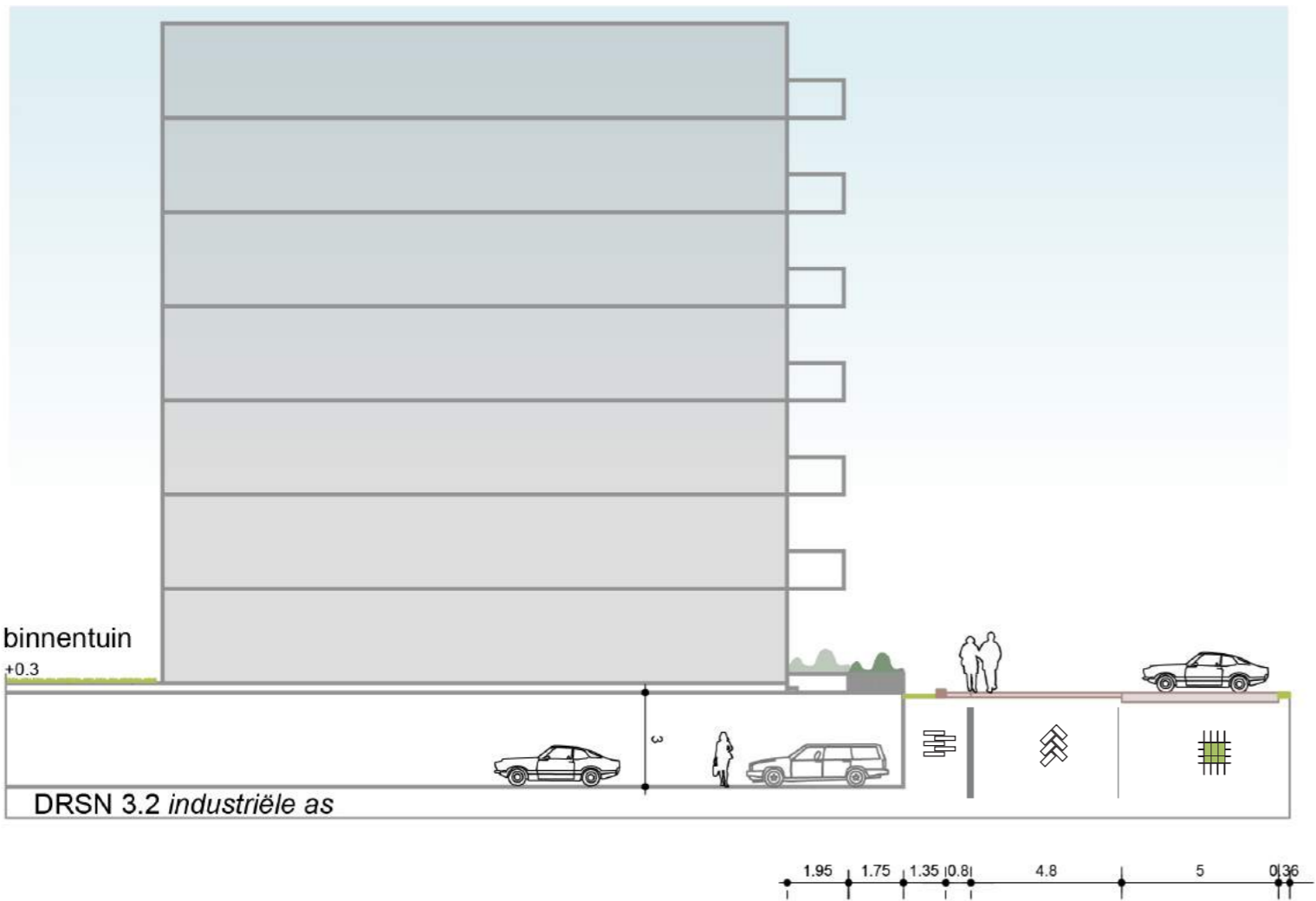

verhoogde plantenbak omkadert buitenruimte



betonnen rand, industrieel karakter



verlaagde band als markering en afwatering



grasbetonstenen met uitstapstrook





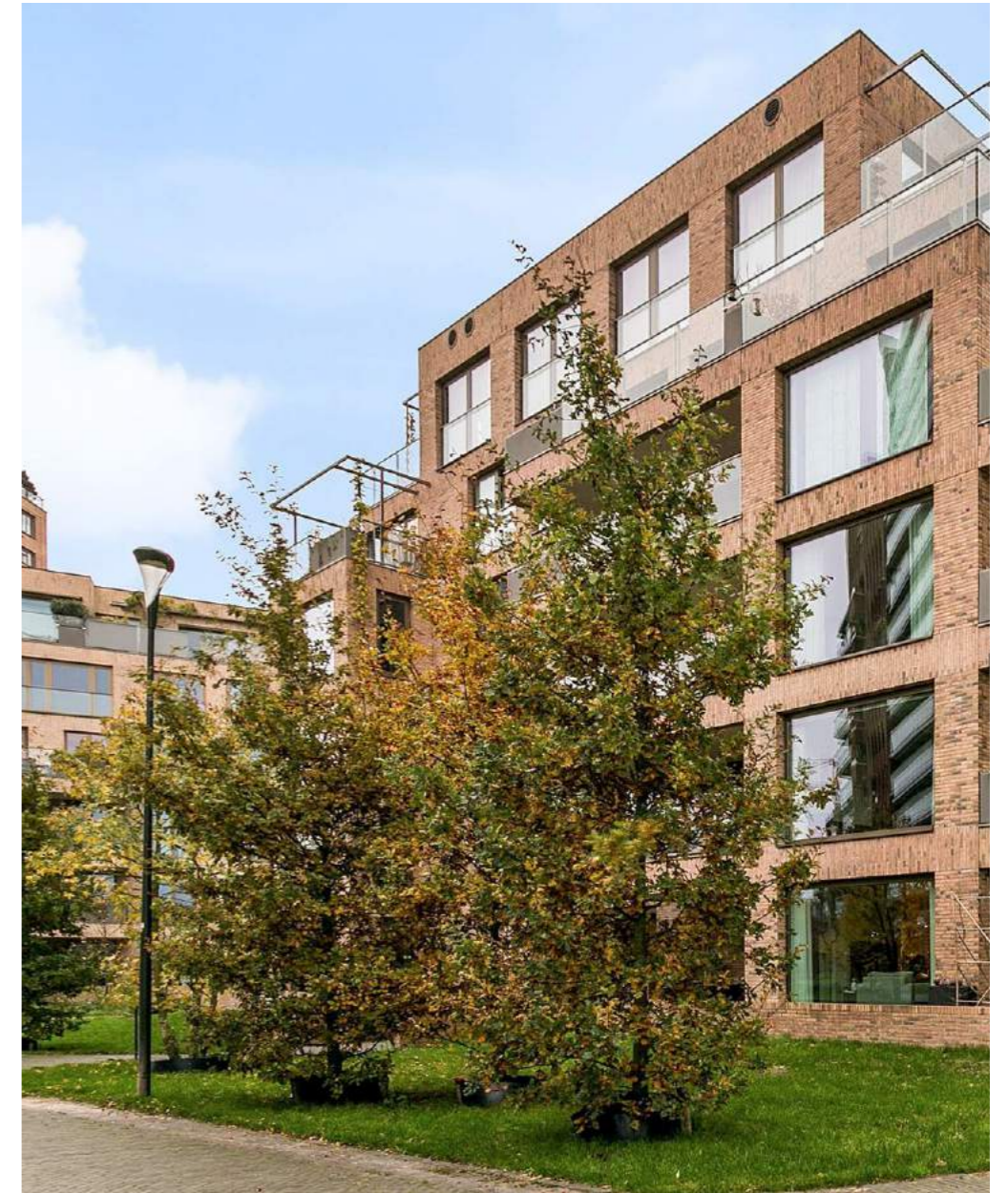
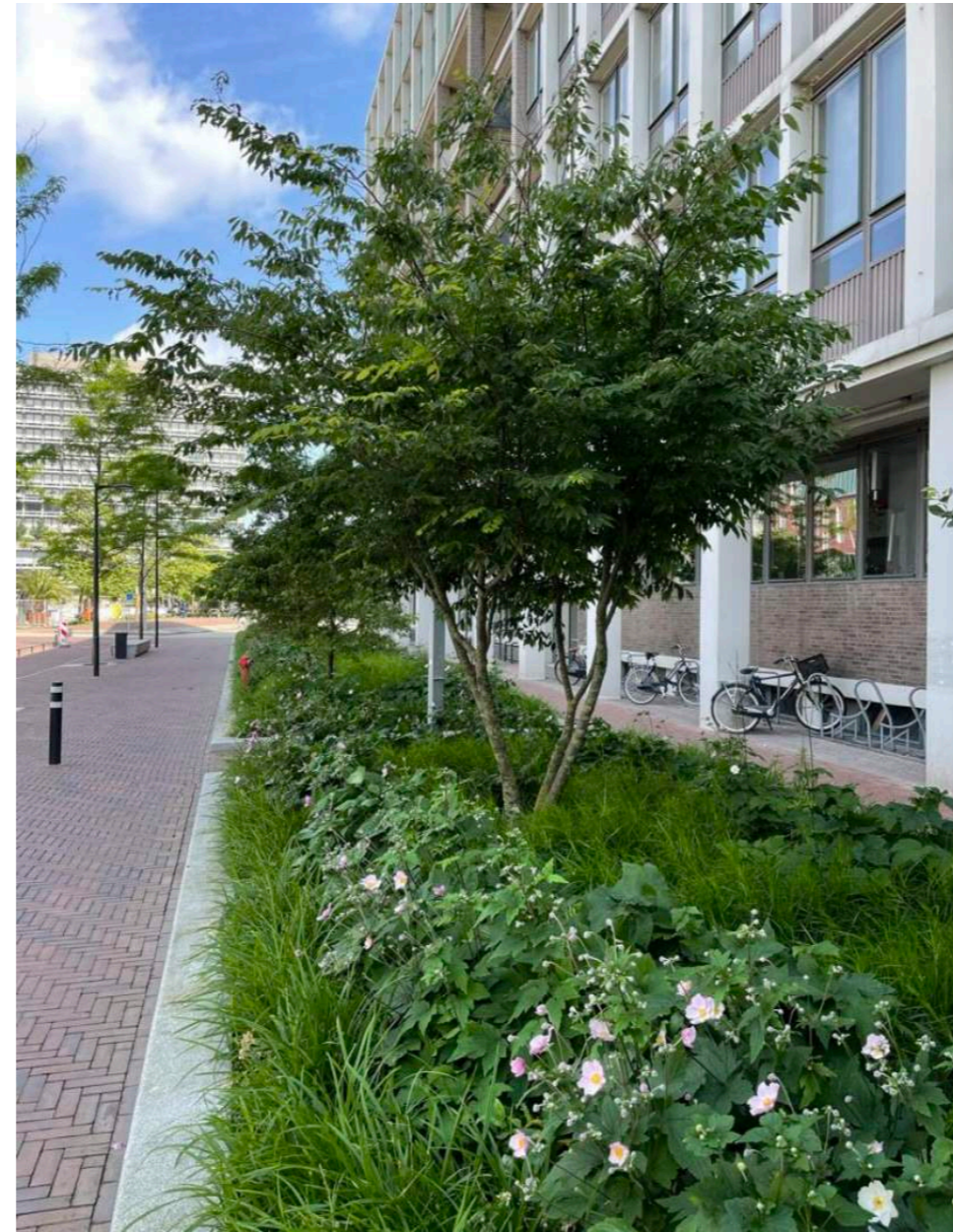

Invulling groen; brede haag, vaste planten onderbegroeiing met meerstammige heesters, gras met bomen ?



rode klinker met smalle loopzone  
 twee verschillende bestratingsverbanden  
 een goot van beton: verwijzing naar inrichting Hokenkwartier

Klimaatadaptief



Parkeervakken met grasbeton



Binnentuin met halfverharding

**Bestratingsmateriaal**

De Vrijheid Hoorn  
 2523 / adviespresentatie  
 13 april 2022



Bouwblokken en hoogte accenten



Bouwblokken korrelgrootte

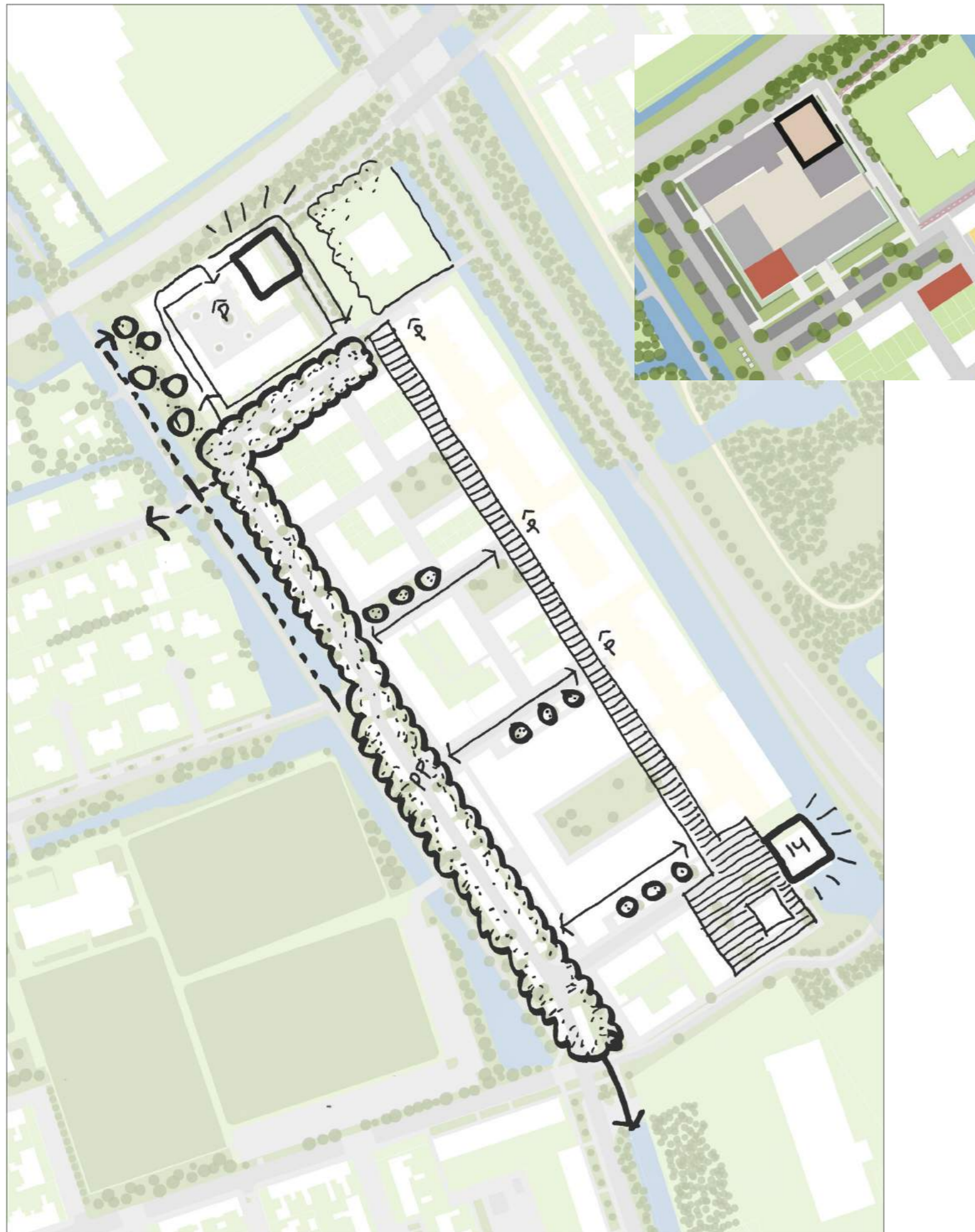

Architectonisch handschrift de Vrijheid

- Modern klassiek
- 1 materiaal
- Minimaal 40% open
- Horizontale en verticale geleding
- Verholen goot, inpandig HWA
- Geen uitstekende dakranden of daklijst
- Geen plint
- Expressie door mestelwerk details en vlakken

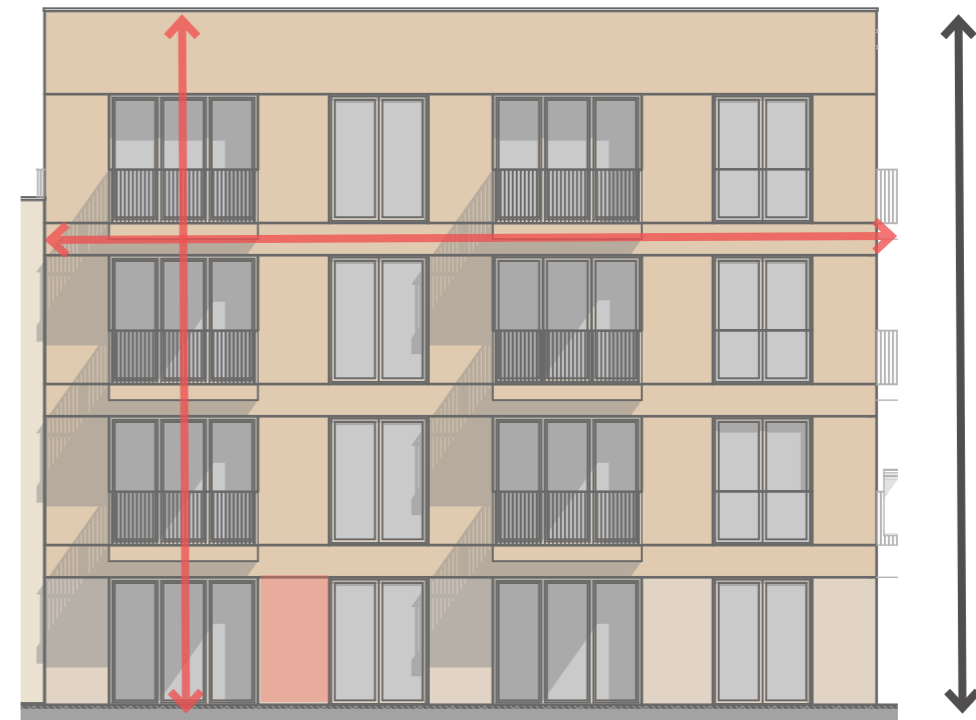

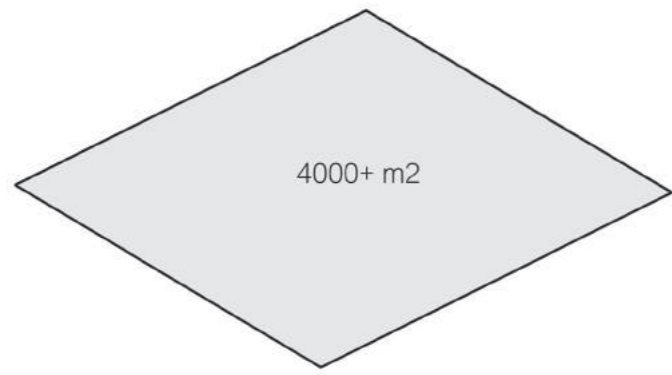

1 Kavel

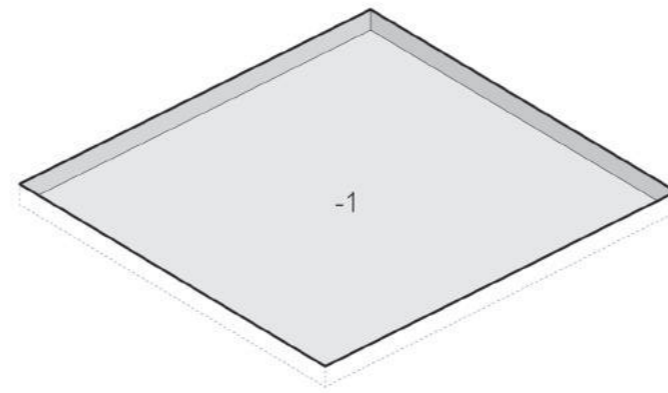

2 Garage

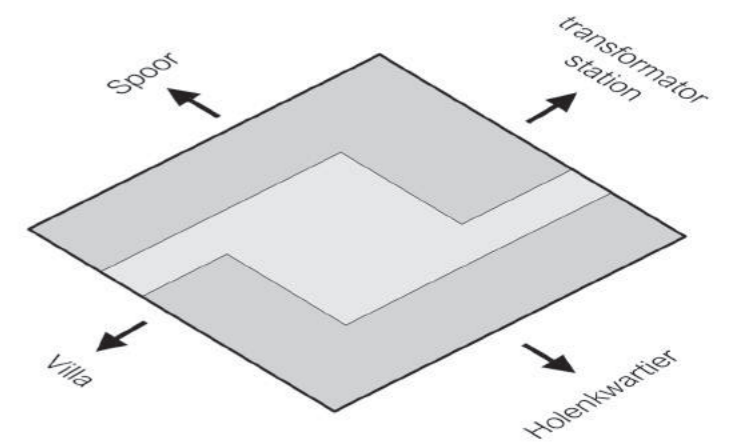

3 Context

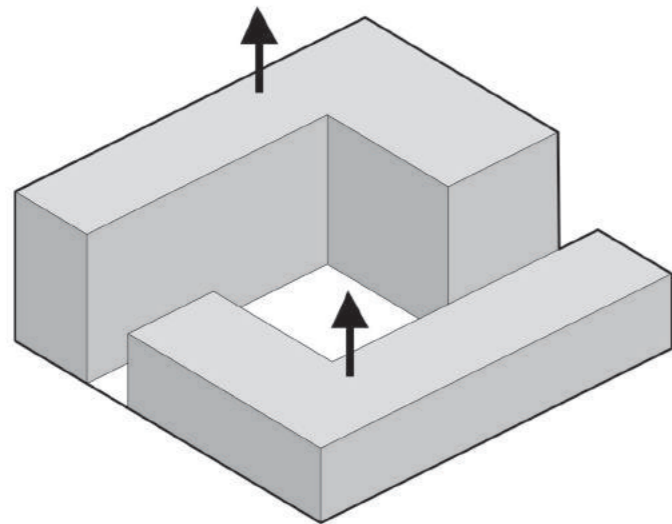

4 Bouwvolume

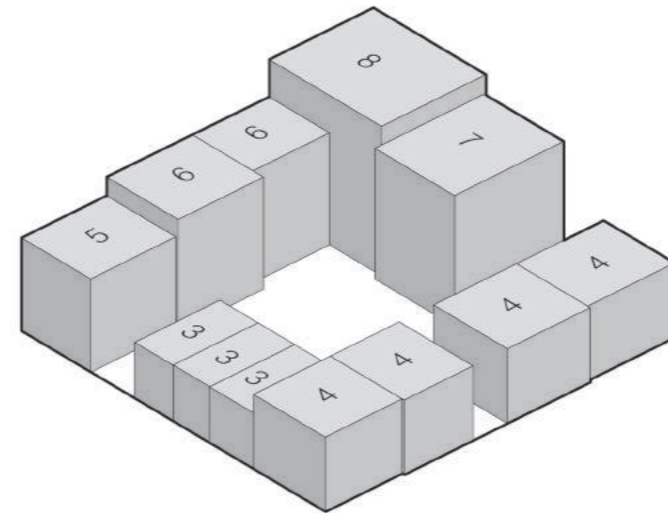

5 Schaal en korrel

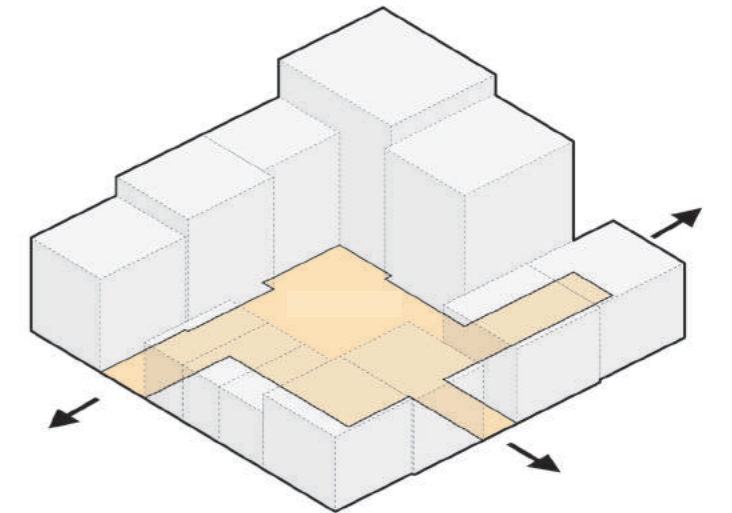

6 Openbare ruimte

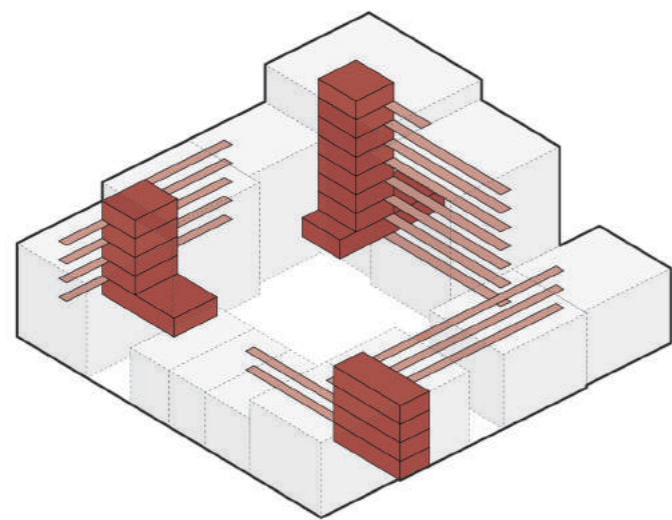

7 Ontsluiting

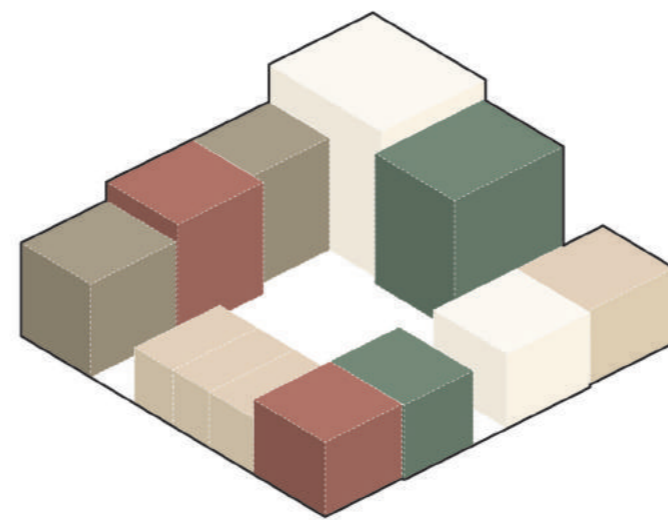

8 Kleur en identiteit

### Stedenbouwkundige schema's

De Vrijheid Hoorn  
2523 / adviespresentatie  
13 april 2022





Holenkwartier  
De Vrijheid Hoorn  
2523 / adviespresentatie  
13 april 2022



Holenkwartier  
De Vrijheid Hoorn  
2523 / adviespresentatie  
13 april 2022

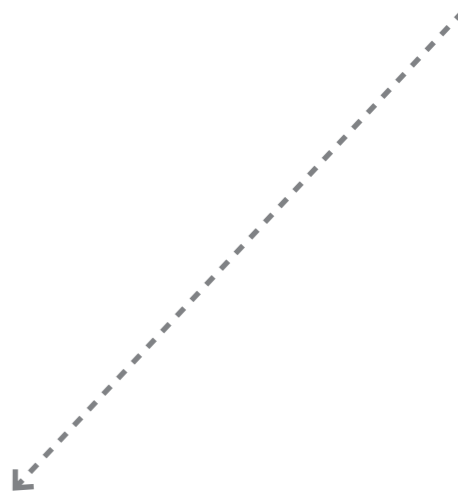
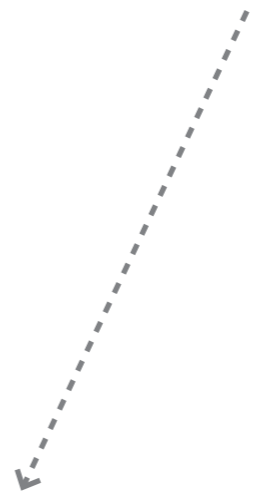
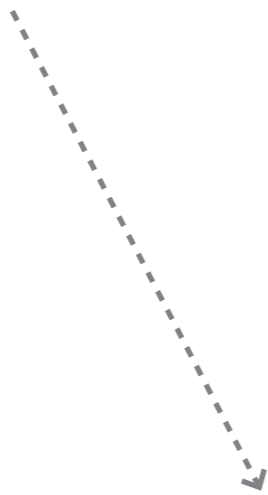
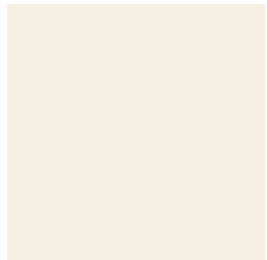
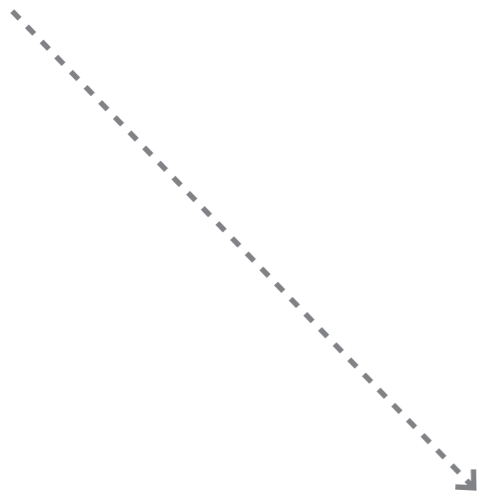

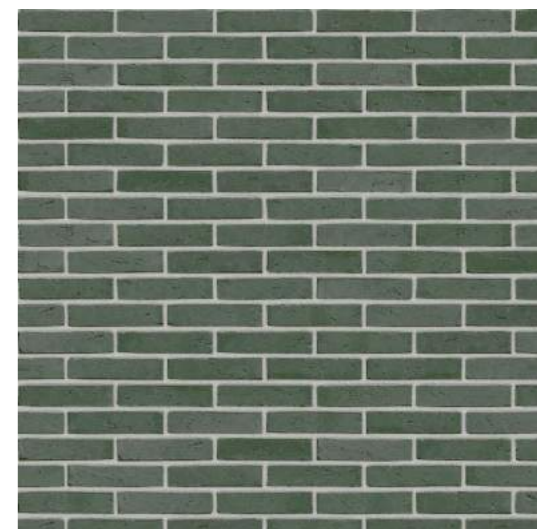
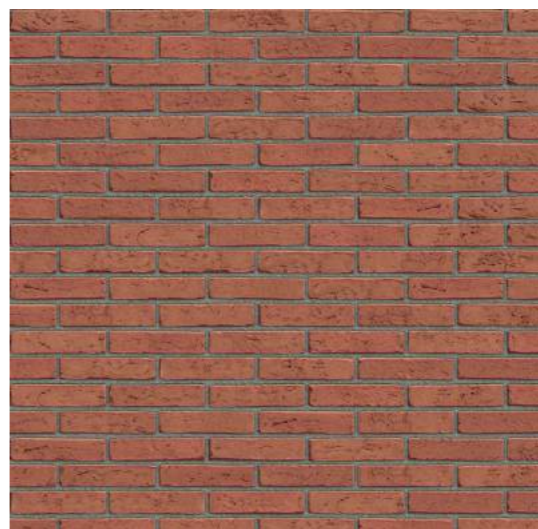
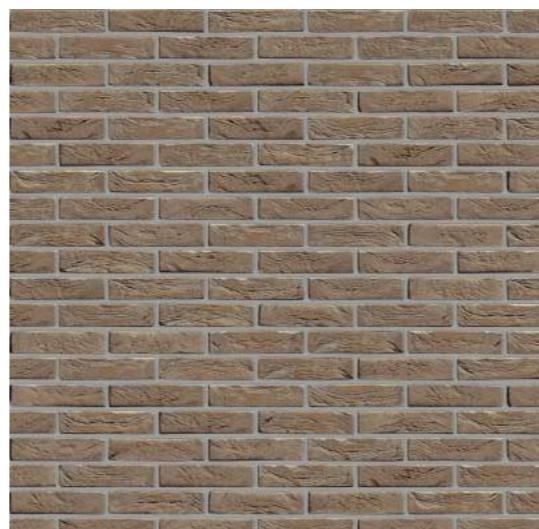
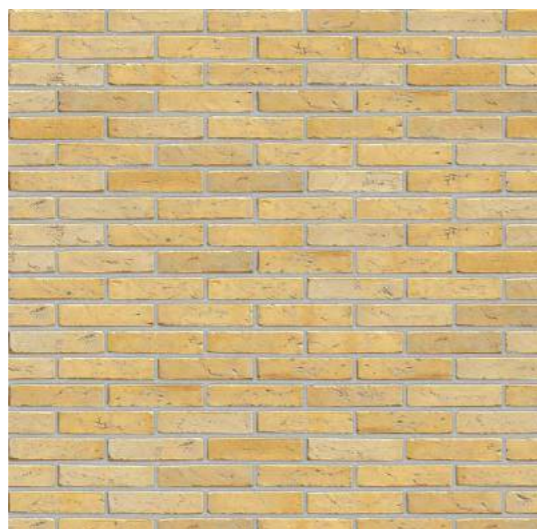
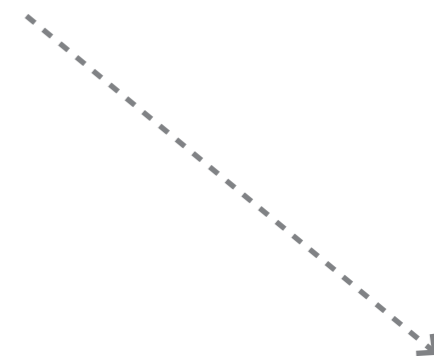
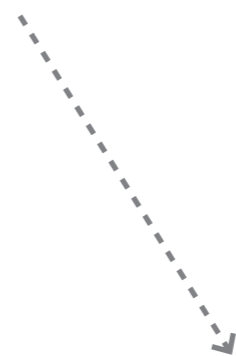
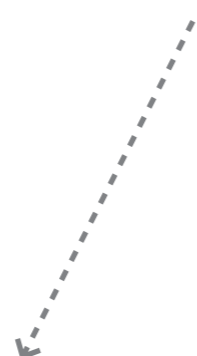
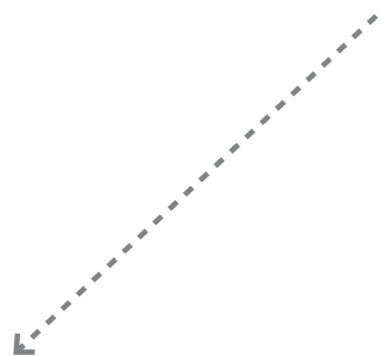
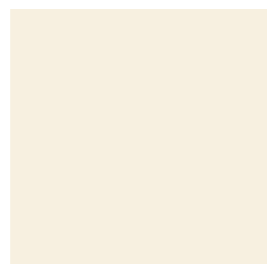

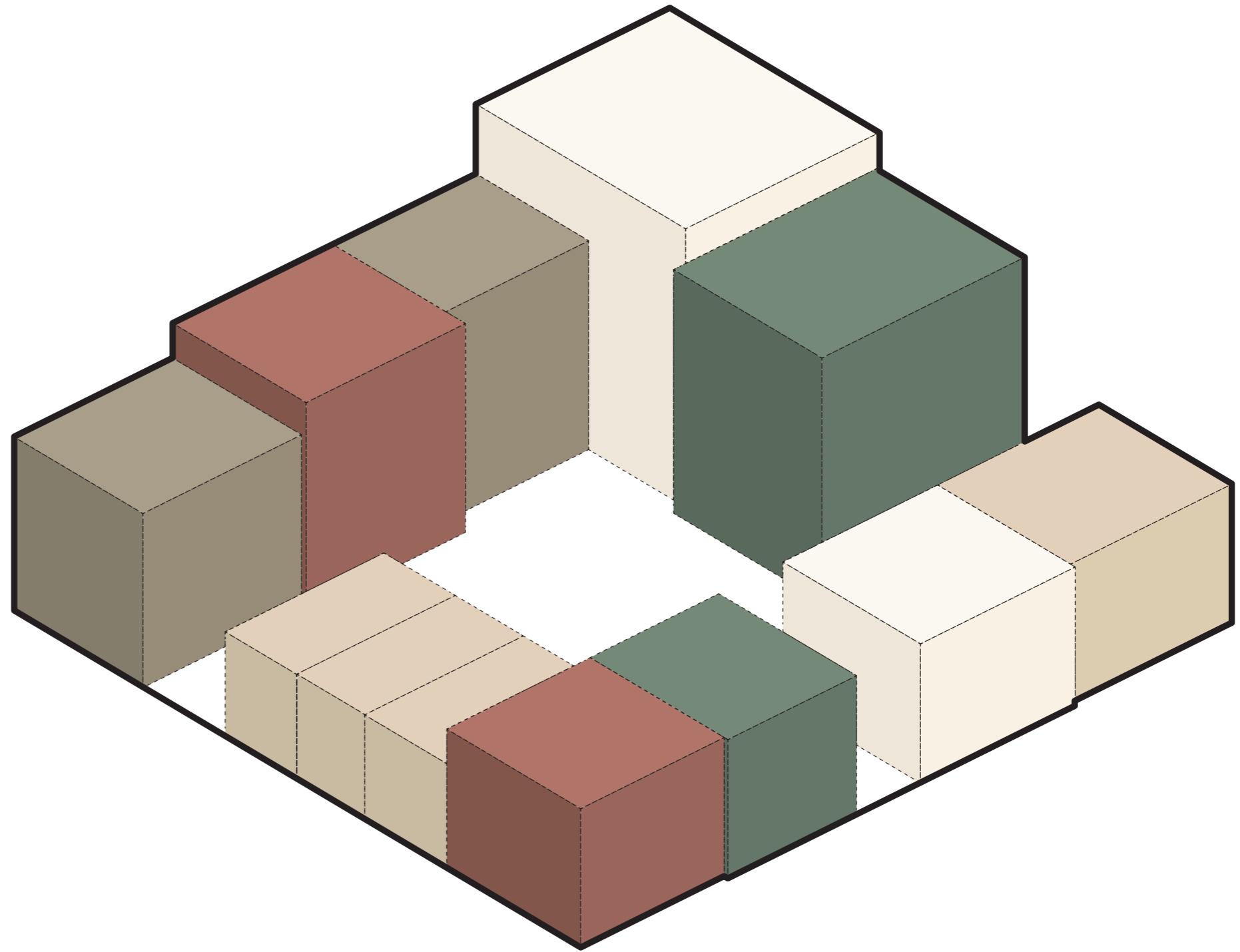
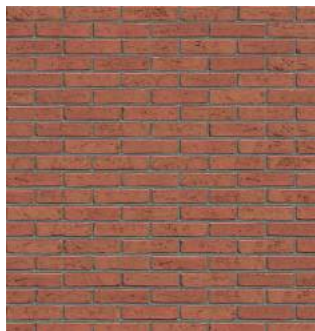
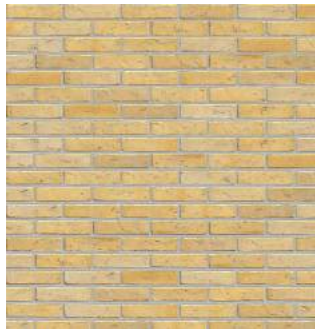



+12.300 vierde verdieping  
+9.300 derde verdieping  
+6.300 tweede verdieping  
+3.300 eerste verdieping  
+300 begane grond

Zuidgevel - zijde Holenkwartier

De Vrijheid Hoorn  
2523 / adviespresentatie  
13 april 2022



Oostgevel - zijde transformatorstation

De Vrijheid Hoorn  
2523 / adviespresentatie  
13 april 2022



Noordgevel - zijde spoor

De Vrijheid Hoorn  
 2523 / adviespresentatie  
 13 april 2022





Westgevel - zijde bestaande wijk

De Vrijheid Hoorn  
2523 / adviespresentatie  
13 april 2022